

ALLOWABLE STRESS DESIGN OF CONCRETE MASONRY

TEK 14-7B
Structural (2009)

INTRODUCTION

Concrete masonry elements can be designed by using one of several methods in accordance with *Building Code Requirements for Masonry Structures* (ref. 1): empirical design, strength design, or allowable stress design. This TEK provides a basic overview of design criteria and requirements for concrete masonry assemblies designed using the allowable stress design provisions contained in Chapter 2 of the *Building Code Requirements for Masonry Structures*. For masonry design in accordance with the empirical or strength design provisions, the reader is referred to TEK 14-8B Empirical Design of Concrete Masonry Walls (ref. 4) and TEK 14-4B Strength Design Provisions for Concrete Masonry (ref. 5), respectively.

The content presented is based upon the requirements of the 2006 International Building Code (ref. 2a) and 2009 International Building Code (ref. 2b), which in turn reference the 2005 and 2008 editions of the *Building Code Requirements for Masonry Structures* (ref. 1a and 1b), respectively. Where design assumptions or modeling conditions differ between cited references, they are identified accordingly here. Otherwise, the allowable stress design provisions between the 2005 and 2008 *Building Code Requirements for Masonry Structures* are the same. This TEK is intended only to provide a general review of the pertinent allowable stress design criteria. Tables, charts,

design examples and additional aids specific to the allowable stress design of concrete masonry elements can be found in the TEK listed in the related TEK box, below.

Allowable stress design is based on the following design principles and assumptions:

- Within the range of allowable stresses, masonry elements satisfy applicable conditions of equilibrium and compatibility of strains.
- Plane sections before bending remain plane after bending. Therefore, masonry strain is directly proportional to the distance from the neutral axis.
- Stress is linearly proportional to strain within the allowable stress range.
- For reinforced masonry design, all tensile stresses are resisted by the steel reinforcement. The contribution of the masonry to the tensile strength of the element is ignored.
- The units, mortar, grout, and reinforcement, if present, act compositely to resist applied loads.

Based on this assumed design model, the internal distribution of stresses and resulting equilibrium is illustrated in Figure 1 for unreinforced masonry and Figure 3 for reinforced masonry.

DESIGN LOADS

Utilizing allowable stress design, masonry elements are sized and proportioned such that the anticipated service level loads can be safely and

Related TEK:
14-3A, 14-5A, 14-15B,
14-19A, 14-20A, 14-22

Keywords: allowable loads, allowable stress, allowable stress design, axial strength, building code provisions, flexural strength, reinforced concrete masonry, shear strength, structural design, unreinforced concrete masonry

economically resisted using the specified material strengths. The specified strength of masonry and reinforcement are in turn reduced by appropriate safety factors. Minimum design loads for allowable stress design are included in *Minimum Design Loads for Buildings and Other Structures* (ref. 3) or obtained from the *International Building Code* (IBC) (ref. 2). For load combinations that include wind or earthquake loads, the code-prescribed allowable stresses are permitted to be increased by one-third when using the alternative basic load combinations of the IBC.

Using allowable stress design, the calculated design stresses on a masonry member (indicated by lowercase f) are compared to code-prescribed maximum allowable stresses (indicated by a capital F). The design is acceptable when the calculated applied stresses are less than or equal to the allowable stresses ($f \leq F$).

UNREINFORCED MASONRY

For unreinforced masonry, the masonry assembly (units, mortar, and grout if used) is designed to carry all applied stresses (see Figure 1). The additional capacity from the inclusion of reinforcing steel, such as reinforcement added for the control of shrinkage cracking or prescriptively required by the code, is neglected. Because the masonry is intended to resist both tension and compression stresses resulting from applied loads, the masonry must be designed to remain uncracked.

Unreinforced Out-of-Plane Flexure

Allowable flexural tension values as prescribed in *Building Code Requirements for Masonry Structures*, vary with the direction of span, mortar type, bond pattern, and percentage of grouting as shown in Table 1. For assemblies spanning horizontally between supports, the code conservatively assumes that masonry constructed in stack bond cannot reliably transfer flexural tension stresses across the head joints. As such, the allowable flexural tension values parallel to the bed joints (perpendicular to the head

joints) for stack bond construction are assumed to be zero for design purposes unless a continuous section of grout crosses the head joint, such as would occur with the use of open-ended units or bond beam units with recessed webs.

Because the compressive strength of masonry is much larger than its corresponding tensile strength, the capacity of unreinforced masonry subjected to net flexural stresses is almost always controlled by the flexural tension values of Table 1. For masonry elements subjected to a bending moment, M , and a compressive axial force, P , the

Table 1—Allowable Flexural Tensile Stresses, psi (kPa)

Direction of flexural tensile stress and masonry type	Mortar types:			
	Portland cement/ lime or mortar cement		Masonry cement or air-entrained portland cement/ lime	
	M or S	N	M or S	N
Normal to bed joints:				
Solid units	40 (276)	30 (207)	24 (166)	15 (103)
Hollow units ^A				
UngROUTED	25 (172)	19 (131)	15 (103)	9 (62)
Fully grouted	65 (448)	63 (434)	61 (420)	58 (400)
Parallel to bed joints in running bond:				
Solid units	80 (552)	60 (414)	48 (331)	30 (207)
Hollow units				
UngROUTED & partially grouted	50 (345)	38 (262)	30 (207)	19 (131)
Fully grouted	80 (552)	60 (414)	48 (331)	30 (207)
Parallel to bed joints in stack bond:				
Continuous grout section parallel to bed joints ^B	100 (690)	100 (690)	100 (690)	100 (690)
Other	0 (0)	0 (0)	0 (0)	0 (0)

^A For partially grouted masonry, allowable stresses shall be determined on the basis of linear interpolation between fully grouted hollow units and ungrouted hollow units based on amount (percentage) of grouting.

^B The 2005 edition of *Building Code Requirements for Masonry Structures* (ref. 1a) does not directly provide for allowable flexural tension stresses parallel to bed joints with continuous grout sections. These design stresses have been clarified in the 2008 edition (ref. 1b).

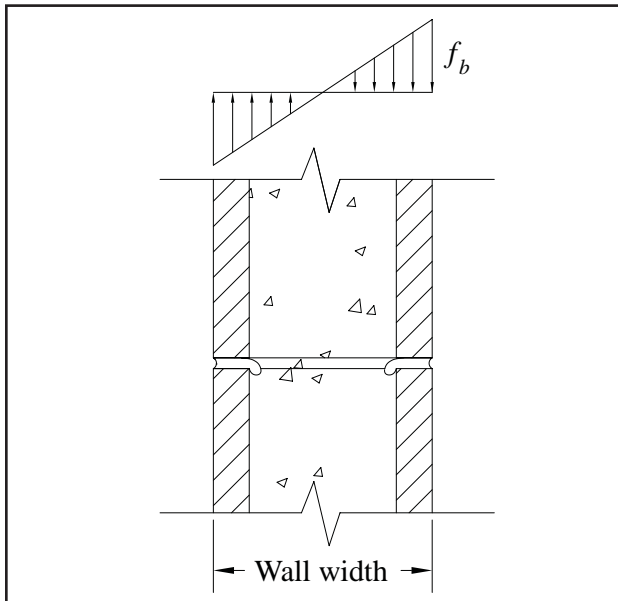

Figure 1—Unreinforced Masonry Stress Distribution

resulting flexural bending stress is determined using Equation 1.

$$f_b = \frac{Mt}{2I_n} - \frac{P}{A_n} \quad \text{Eqn. 1}$$

TEK 14-1B, *Section Properties of Concrete Masonry Walls* (ref. 6) provides typical values for the net moment of inertia, I_n , and cross-sectional area, A_n , for various wall sections. If the value of the bending stress, f_b , given by Equation 1 is positive, the masonry section is controlled by tension and the limiting values of Table 1 must be satisfied. Conversely, if f_b as given by Equation 1 is negative, the masonry section is in compression and the compressive stress limitation of Equation 2 must be met.

$$f_b \leq F_b = \frac{1}{3} f'_m \quad \text{Eqn. 2}$$

Unreinforced Axial Compression and Flexure

While unreinforced masonry can resist flexural tension stresses due to applied loads, unreinforced masonry may not be subjected to net axial tension, such as that due to wind uplift on a roof connected to a masonry wall or the overturning effects of lateral loads. While compressive stresses from dead loads can be used to offset tensile stresses, reinforcement must be incorporated to resist the resulting tensile forces when

the element is subject to a net axial tension.

When masonry elements are subjected to compressive axial loads only, the calculated compressive stress due to applied load, f_a , must not exceed the allowable compressive stress, F_a , as given by Equations 3 or 4, as appropriate.

For elements having $h/r \leq 99$:

$$f_a \leq F_a = \frac{1}{4} f'_m \left[1 - \left(\frac{h}{140r} \right)^2 \right] \quad \text{Eqn. 3}$$

For elements having $h/r > 99$:

$$f_a \leq F_a = \frac{1}{4} f'_m \left(\frac{70r}{h} \right)^2 \quad \text{Eqn. 4}$$

A further check for stability against an eccentrically applied axial load is included with Equation 5, whereby the axial compressive load, P , is limited to one-fourth the buckling load, P_e . With Equation 5, the actual eccentricity of the applied load, e , is used to determine P_e . Moments on the assembly due to loads other than the eccentric load are not considered in Equation 5.

$$P \leq \frac{1}{4} P_e = \frac{1}{4} \left(\frac{\pi^2 E_m I_n}{h^2} \right) \left(1 - 0.577 \frac{e}{r} \right)^3 \quad \text{Eqn. 5}$$

When unreinforced masonry elements are subjected to a combination of axial load and flexural bending, a unity equation is used to proportion the available allowable stresses to the applied loads per Equation 6. This check ensures that the critical sections remain uncracked under design loads.

$$\frac{f_a}{F_a} + \frac{f_b}{F_b} \leq 1 \quad \text{Eqn. 6}$$

Unreinforced Shear

Shear stresses on unreinforced masonry elements are calculated using the net cross-sectional properties of the masonry in the direction of the applied shear force using the following relation:

$$f_v = \frac{VQ}{I_n b} \quad \text{Eqn. 7}$$

Equation 7 is applicable to determining both in-plane and out-of-plane shear stresses. Because unreinforced masonry is designed to remain uncracked, it is not necessary to perform a cracked section analysis to determine the net cross-sectional area of the masonry.

The theoretical distribution of shear stress, f_v , along the length of the shear wall (Figure 2)

for in-plane loads, or perpendicular to any wall for out-of-plane loads, is parabolic in shape for a rectangular cross-section. The calculated shear stress due to applied loads, f_v , as given by Equation 7 cannot exceed any of the code-prescribed allowable shear stresses, F_v , as follows:

- a) $1.5\sqrt{f'_m}$ psi (0.125 $\sqrt{f'_m}$ MPa)
- b) 120 psi (827 kPa)
- c) For running bond masonry not grouted solid:
37 psi + 0.45 N_v/A_n (255 + 0.45 N_v/A_n kPa)
- d) For stack bond masonry with open end units and grouted solid:
37 psi + 0.45 N_v/A_n (255 + 0.45 N_v/A_n kPa)
- e) For running bond masonry grouted solid:
60 psi + 0.45 N_v/A_n (414 + 0.45 N_v/A_n kPa)
- f) For stack bond masonry other than open end units grouted solid: 15 psi (103 kPa)

Building Code Requirements for Masonry Structures defines the above allowable shear stresses as being applicable to in-plane shear stresses only: allowable shear stresses for out-of-plane loads are not provided. In light of this absence, *Commentary on Building Code Requirements for Masonry Structures* suggests using these same values for out-of-plane shear design.

REINFORCED MASONRY

Reinforced masonry design in accordance with *Building Code Requirements for Masonry Structures* neglects the tensile resistance provided by the masonry units, mortar and grout in determining the strength of the masonry assemblage. Thus, for design purposes, the portion of masonry subjected to net tensile stresses is assumed to have cracked, transferring all tensile forces to the reinforcement. (While the determination of the reinforced masonry element strength conservatively assumes the portion of the masonry subjected to net tensile stresses has cracked, this should be verified when calculating the stiffness and deflection of a reinforced masonry element.)

Reinforcement

The tensile stress in the reinforcement due to applied load, f_s , is calculated as the product of the strain in the steel (which increases linearly in proportion to the distance from the neutral axis) and its modulus of elasticity, E_s . The modulus

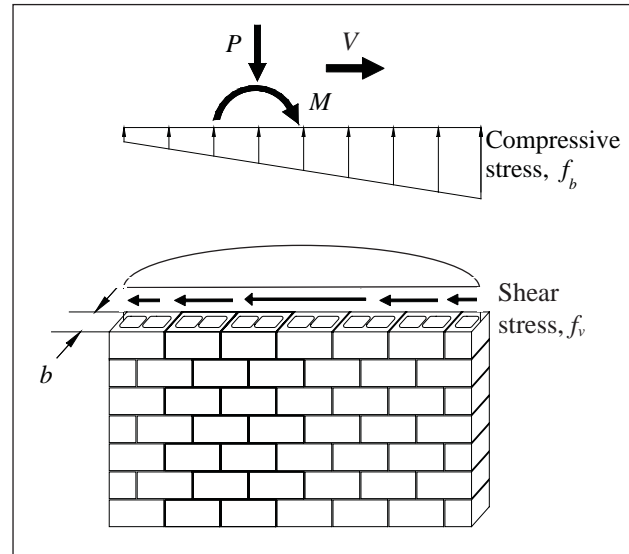

Figure 2—Unreinforced Masonry Shear Walls

of elasticity, E_s , of mild steel reinforcement is assumed to be 29,000,000 psi (200 GPa). The code-prescribed allowable steel stresses are as follows (ref. 1):

For Grade 60 reinforcement in tension:

$$F_s = 24,000 \text{ psi (165.5 MPa)}$$

For Grade 40 and 50 reinforcement in tension:

$$F_s = 20,000 \text{ psi (137.9 MPa)}$$

For wire reinforcement in tension:

$$F_s = 30,000 \text{ psi (206.9 MPa)}$$

For all reinforcement in compression:

$F_s = 24,000 \text{ psi (165.5 MPa)}$ or $0.4f_y$, whichever is less.

Unless ties or stirrups laterally confine the reinforcement as required by *Building Code Requirements for Masonry Structures*, the reinforcement is assumed not to contribute compressive resistance to axially loaded elements. Additional information on mild reinforcing steel can be found in TEK 12-4D, *Steel Reinforcement for Concrete Masonry* (ref. 7).

Reinforced Out-of-Plane Flexure

As with unreinforced masonry, the allowable compressive stress in masonry, F_b , due to flexure or due to a combination of flexure and axial load is limited by Equation 2. When axial loads are not present, or are conservatively neglected as may be appropriate in some cases, there are several circumstances to consider in determin-

ing the flexural capacity of reinforced masonry assemblies.

For a fully grouted element, a cracked transformed section approach is used, wherein the reinforcement area is transformed to an equivalent area of concrete masonry using the modular ratio.

Partially grouted assemblies are analyzed in the same way, but with the additional consideration of the ungrouted cores. For partially grouted masonry there are two types of behavior to consider.

1. The first case applies when the neutral axis (the location of zero stress) lies within the compression face shell, as shown in Figure 3A. In this case, the masonry is analyzed and designed using the procedures for a fully grouted assembly.
2. The second type of analysis occurs when the neutral axis lies within the core area rather than the compression face shell, as shown in Figure 3B. For this case, the portion of the ungrouted cells must be deducted from the area of masonry capable of carrying compression stresses.

The neutral axis location depends on the relative moduli of elasticity of the masonry and steel, n , as well as the reinforcement ratio, ρ , and the distance between the reinforcement and extreme compression fiber, d .

When analyzing partially grouted assemblies, it is typically assumed that the neutral axis lies within the compression face shell, as the analysis is more straightforward. Based on this assumption, the resulting value of k and the location of the neutral axis (kd) is calculated. If it is determined that the neutral axis lies outside the compression face shell, the more rigorous tee beam analysis is performed. Otherwise, the rectangular beam analysis is carried out. A complete discussion and derivation of this procedure is contained in *Concrete Masonry Design Tables* (ref. 8).

For design purposes, the effective width of the compression

zone per bar is limited to the smallest of:

- six times the wall thickness,
- the center-to-center spacing of the reinforcement, or
- 72 in. (1,829 mm).

This requirement applies to masonry constructed in running bond and to masonry constructed in stack bond containing bond beams spaced no farther than 48 in. (1,219 mm) on center. Where the center-to-center spacing of the reinforcement does not control the effective width of the compression zone, the resulting resisting moment or resisting shear is proportioned over the width corresponding to the effective width of the compression zone as determined above.

Rectangular Beam Analysis

For fully grouted masonry elements and for partially grouted masonry elements with the neutral axis in the compression face shell, the resisting flexural capacity, M_r , is calculated as follows:

$$n = E_s/E_m \quad \text{Eqn. 8}$$

$$\rho = \frac{A_s}{bd} \quad \text{Eqn. 9}$$

$$k = \sqrt{2\rho n + (\rho n)^2} - \rho n \quad \text{Eqn. 10}$$

$$j = 1 - k/3 \quad \text{Eqn. 11}$$

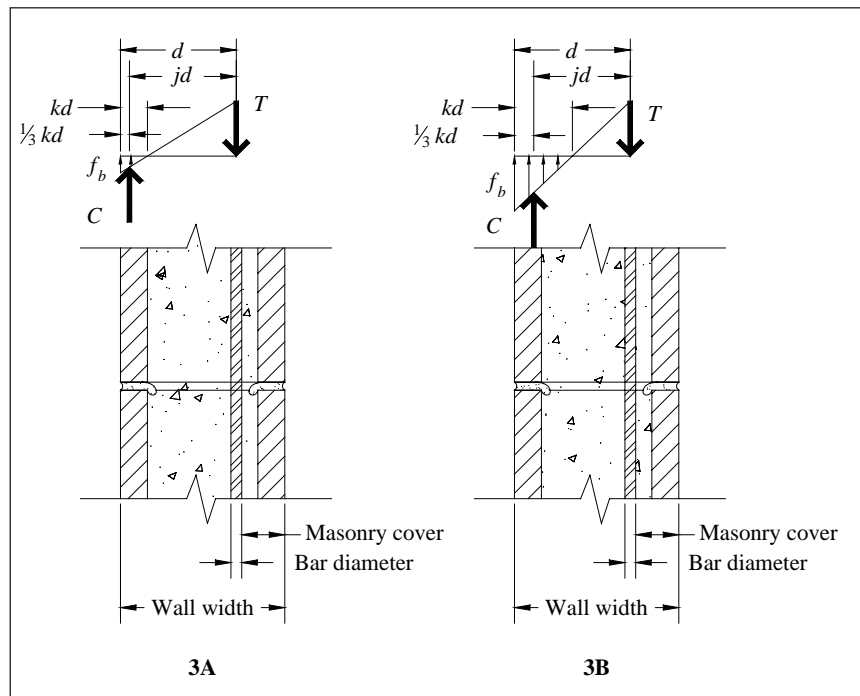

Figure 3—Reinforced Masonry Stress Distribution

$$M_m = \frac{1}{2} F_b k j b d^2 \quad \text{Eqn. 12}$$

$$M_s = A_s F_s j d \quad \text{Eqn. 13}$$

Where the resisting flexural capacity, M_r , is taken as the lesser of M_m and M_s .

Tee Beam Analysis

For partially grouted masonry assemblies where the neutral axis is located within the cores (i.e., when the use of Equation 10 results in $k d$ occurring outside of the compression face shell), the resisting flexural capacity, M_r , is calculated using the neutral axis coefficient k given by Equation 14 and either Case A or Case B as follows:

$$k = \frac{-t_{fs}(b - b_w) - A_s n}{db_w} + \frac{\sqrt{(t_{fs}(b - b_w) + A_s n)^2 + b_w(t_{fs}^2(b - b_w) + 2A_s n d)}}{db_w} \quad \text{Eqn. 14}$$

(A) For cases where the masonry strength controls the design capacity:

$$f_s = n F_b \left(\frac{1 - k}{k} \right) \quad \text{Eqn. 15}$$

If f_s as determined using Equation 15 is greater than the allowable steel stress, F_s , then the steel controls the strength and the design is carried out using procedure (B) below. Otherwise, the internal compression force, C , and moment capacity are computed as follows:

$$C = \frac{1}{2} F_b b k d \quad \text{Eqn. 16}$$

$$M_r = C j d \quad \text{Eqn. 17}$$

(B) For cases where the steel strength controls:

$$T = A_s F_s \quad \text{Eqn. 18}$$

$$M_r = T j d \quad \text{Eqn. 19}$$

(C) The shear capacity in both cases is calculated as follows:

$$V_r = F_v b d \quad \text{Eqn. 21}$$

Reinforced Axial Compression

Axial loads acting through the axis of a member are distributed over the net cross-sectional area of the effective compression zone, or, for concentrated loads, $4t$ plus the bearing width.

The allowable axial compressive force is based on the compressive strength of masonry and the slenderness ratio of the element in accordance with the following:

For elements having $h/r \leq 99$, the allowable compressive force, P_a , is determined as follows:

$$P_a = (0.25f'_m A_n + 0.65A_s F_s) \left[1 - \left(\frac{h}{140r} \right)^2 \right] \quad \text{Eqn. 23}$$

For elements having $h/r > 99$, the allowable compressive force, P_a , is determined as follows:

$$P_a = (0.25f'_m A_n + 0.65A_s F_s) \left(\frac{70r}{h} \right)^2 \quad \text{Eqn. 24}$$

Note that compression reinforcement requires ties or stirrups to laterally confine the reinforcement.

Reinforced Axial Compression and Flexure

Often, loading conditions result in both axial load and flexure on a masonry element. Superimposing the stresses resulting from axial compression and flexural compression produces the combined stress. Members are proportioned so that this maximum combined stress does not exceed the allowable stress limitation imposed by Equation 2, 5, 6, and either Equation 23 or 24, as appropriate. In cases where the combined compressive stresses are relatively large, design economy may be realized by increasing the specified masonry compressive strength, f'_m , which in turn can result in thinner wall cross-sections, reduced material usage, and increased construction productivity. Several design approaches are available for combined axial compression and flexure, most commonly using either computer programs to perform the necessary iterative calculations or using interaction diagrams to graphically determine the required reinforcement for a given condition (refs. 8, 9, 10).

Reinforced Shear

Shear acting on masonry flexural members and shear walls is resisted either by the masonry (units, mortar and grout) or by shear reinforcement. For masonry members not subjected to flexural tension, the allowable shear stresses provided earlier for unreinforced masonry apply. For masonry elements that are subjected to flexural tension, the applied shear stress is calculated as follows:

$$f_v = \frac{V}{bd} \quad \text{Eqn. 25}$$

Where reinforcement is not provided to resist the entire calculated shear stress, f_v , the allowable shear stress, F_v , is required to be determined in accordance with the following:

For flexural members:

$$F_v = \sqrt{f'_m} \leq 50 \text{ psi (345 kPa)} \quad \text{Eqn. 26}$$

For shear walls:

Where M/Vd is < 1 :

$$F_v = \frac{1}{3} \left(4 - \left(\frac{M}{Vd} \right) \right) \sqrt{f'_m} \leq 80 - 45 \left(\frac{M}{Vd} \right) \quad \text{Eqn. 27}$$

Where M/Vd is ≥ 1 :

$$F_v = \sqrt{f'_m} \leq 35 \text{ psi (241 kPa)} \quad \text{Eqn. 28}$$

When shear reinforcement is provided to resist the entire shear force, the minimum amount of shear reinforcement is determined by Equation 29.

$$A_v = \frac{Vs}{F_s d} \quad \text{Eqn. 29}$$

Where reinforcement is provided to resist the entire calculated shear stress, f_v , the allowable shear stress, F_v , is required to be determined in accordance with the following:

For flexural members:

$$F_v = 3\sqrt{f'_m} \leq 150 \text{ psi (1,034 kPa)} \quad \text{Eqn. 30}$$

For shear walls:

Where M/Vd is < 1 :

$$F_v = \frac{1}{2} \left(4 - \left(\frac{M}{Vd} \right) \right) \sqrt{f'_m} \leq 120 - 45 \left(\frac{M}{Vd} \right) \quad \text{Eqn. 31}$$

Where M/Vd is ≥ 1 :

$$F_v = 1.5\sqrt{f'_m} \leq 75 \text{ psi (517 kPa)} \quad \text{Eqn. 32}$$

For Equations 27, 28, 31 and 32, the ratio M/Vd is required to be taken as a positive value.

Providing shear reinforcement in accordance with Equations 29 through 32, must also comply with the following:

- Shear reinforcement is oriented parallel to the direction of the shear force.
- Shear reinforcement spacing must not exceed the lesser of $d/2$ or 48 in. (1,219 mm).
- Reinforcement must also be provided perpendicular to the shear reinforcement. This prescriptive reinforcement must have an area of at least one-third A_v as given by Equation 29 and may not be spaced farther apart than 8 ft (2,438 mm).

NOTATION

A_n = net cross-sectional area of masonry, in.² (mm²)

A_s = effective cross-sectional area of reinforcement, in.² (mm²)

A_v = effective cross-sectional area of shear reinforcement, in.² (mm²)

b = width of section, in. (mm)

b_w = for partially grouted walls, width of grouted cell plus each web thickness within the compression zone, in. (mm)

C = resultant compressive force, lb (N)

d = distance from the extreme compression fiber to the centroid of the tension reinforcement, in. (mm)

E_m = modulus of elasticity of masonry, psi (MPa)

E_s = modulus of elasticity of reinforcement, psi (MPa)

e = eccentricity of applied load, lb (N)

F_a = allowable compressive stress due to axial load, psi (MPa)

f_a = calculated compressive stress due to axial load, psi (MPa)

F_b = allowable bending stress due to flexure, psi (MPa)

f_b = calculated bending stress due to flexure, psi (MPa)

f'_m = specified compressive strength of masonry, psi (MPa)

F_s = allowable tensile or compressive stress in reinforcement, psi (MPa)

f_s = calculated tensile or compressive stress in reinforcement, psi (MPa)

F_v = allowable shear stress, psi (MPa)

f_v = calculated shear stress, psi (MPa)

f_y = specified yield strength of reinforcement, psi (MPa)

h = effective height of masonry element, in. (mm)

I_n = moment of inertia of net cross-sectional area of a masonry element, in.⁴ (mm⁴)

j = ratio of distance between centroid of flexural compressive forces and centroid of tensile forces to depth d

k = ratio of distance between compression face of element and neutral axis to the effective depth d

M = maximum calculated bending moment at section under consideration, in.-lb, (N-mm)

M_m = flexural strength (resisting moment) when masonry controls, in.-lb (N-mm)

M_r = flexural strength (resisting moment), in.-lb (N-mm)

M_s = flexural strength (resisting moment) when reinforcement controls, in.-lb (N-mm)
 N_v = compressive force acting normal to the shear surface, lb (N)
 n = modular ratio
 P = applied axial load, lb (N)
 P_a = allowable compressive force in reinforced masonry due to axial load, lb (N)
 P_e = Euler buckling load, lb (N)
 Q = first moment of inertia about the neutral axis, in.³ (mm³)

r = radius of gyration, in. (mm)
 s = spacing of shear reinforcement, in. (mm)
 T = resultant tensile force, lb (N)
 t = thickness of masonry element, in. (mm)
 t_{fs} = concrete masonry unit face shell thickness, in. (mm)
 V = applied shear force, lb (N)
 V_r = shear capacity (resisting shear) of masonry, lb (N)
 ρ = reinforcement ratio

REFERENCES

1. *Building Code Requirements for Masonry Structures*, Reported by the Masonry Standards Joint Committee.
 - a. 2005 Edition: ACI 530-05/ASCE 5-05/TMS 402-05
 - b. 2008 Edition: TMS 402-08/ACI 530-08/ASCE 5-08
2. *International Building Code*. International Code Council.
 - a. 2006 Edition
 - b. 2009 Edition
3. *Minimum Design Loads for Buildings and Other Structures*, ASCE 7-05. American Society of Civil Engineers, 2005.
4. *Empirical Design of Concrete Masonry Walls*, TEK 14-8B. National Concrete Masonry Association, 2008.
5. *Strength Design Provisions for Concrete Masonry*, TEK 14-4B. National Concrete Masonry Association, 2008.
6. *Section Properties of Concrete Masonry Walls*, TEK 14-1B. National Concrete Masonry Association, 2007.
7. *Steel Reinforcement for Concrete Masonry*, TEK 12-4D. National Concrete Masonry Association, 2007.
8. *Concrete Masonry Design Tables*, TR121. National Concrete Masonry Association, 2000.
9. *Structural Masonry Design System*, Version 4.0, CMS10, National Concrete Masonry Association, 2006.
10. *Loadbearing Concrete Masonry Wall Design*, TEK 14-5A. National Concrete Masonry Association, 2006.

NCMA and the companies disseminating this technical information disclaim any and all responsibility and liability for the accuracy and the application of the information contained in this publication.



NATIONAL CONCRETE MASONRY ASSOCIATION
13750 Sunrise Valley Drive, Herndon, Virginia 20171
www.ncma.org

To order a complete TEK Manual or TEK Index, contact NCMA Publications (703) 713-1900
